

ISG-A104

Features

- Amplifier with modulated infrared light
- Range up to 50 m (164 ft)
- High immunity to ambient light and interference from other light barriers
- Automatic Level Control (ALC) according to assembly distance and direction
- Test function to check installation and signal strength
- Programmable light/dark function
- Four basic transmit levels
- Transmission channel frequency selection by dip-switch
- Relay output (1 changeover)
- Transmitter and receiver connections are short-circuit proof
- 11-pin DIN rail mounting socket for simple installation

Ordering Table

Supply voltage	Order code
230 V AC	ISG-A104/230VAC
115 V AC	ISG-A104/115VAC
24 V AC	ISG-A104/24VAC
24 V DC	ISG-A104/24VDC

Accessories	Order code
11-pin DIN mounting socket	ISO1
Protective enclosure	PanBox 1x1
Retaining clip	RTC11

Safety Instructions



Warning!

The infrared light barriers ISG-... are not safety systems and should not be used as such systems. The devices are not to be used for applications, where personal safety is dependent on their function.

Short Description

This 1-channel automatic amplifier has set a new standard for devices of this type. It is an amplifier with an integrated analysis unit. The automatic gain setting enables the user to simplify the installation and work.

The amplifier can be switched to the different working conditions by DIP-switches. The sensitivity of the device can be switched to 4 basic transmit levels using the same method. Also, the transmitter power can be increased to optimize object recognition.

The amplifier can be switched to a different switching mode by using a bridge at the socket.

A control unit, which can be activated by simply pressing a button, is used to determine malfunctions in the transmitter or the receiver. If nothing is defective, the test function shows the signal quality by flashing an LED from 1 to 10 times. The flashes are proportional to the received signal.

An alarm display and output, which shows errors and the limit of the transmit power and is connectable with a PLC, enables users to safely work with the photoelectric amplifier.

Infrared transmitters and receivers in different, compact and robust designs are described in the sensor heads datasheet.



Device Overview

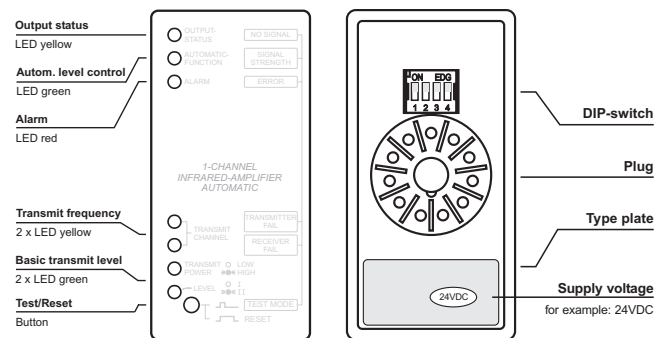

Dip-switch setting

DIP-switch	1	2	3	4
	Basic transmit level		Transmit frequency	
High 2	ON	ON	4,10 kHz	ON
High 1	ON	OFF	3,97 kHz	ON
Low 2	OFF	ON	3,85 kHz	OFF
Low 1	OFF	OFF	3,70 kHz	OFF

Factory setting is marked in dark grey

Switching logic

Beam status	Switching mode	Output status	
		Indicator	Relay output
→ →	light	⊗	① ③ ④
→ →	dark	⊗	① ③ ④
→ →	light	⊗	① ③ ④
→ →	dark	⊗	① ③ ④

Dimensions (in mm)

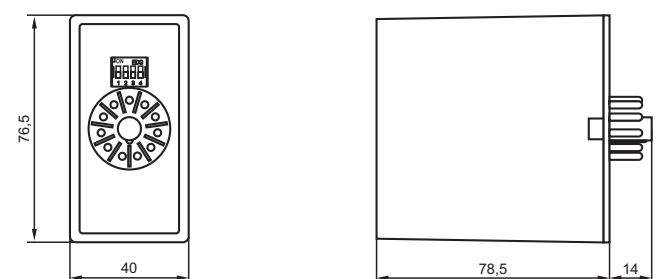

ISG-A104

Technical Data (at 20 °C / 68 °F)

Supply voltage ...AC	230/115/24 V AC / ±10%	
Supply voltage ...DC	24 V DC / ±10%	
Power consumption (max.)	...AC: 4,1 VA	...DC: 1,9 W
Power loss (max.) (EN 61439)	...230VAC : 3,4 W	...24VDC: 1,9 W
	...115VAC : 3,4 W	
	...24VAC : 3,2 W	
max. Range (through beam)	Receiver IRL-...	Receiver IR-..., IRH-...
Transmitter IT-..., ITL-...	7 m (23 ft)	15 m (49 ft)
Transmitter IT-...HP, ITH-...	12 m (39 ft)	25 m (82 ft)
Transmitter ITA-...	20 m (66 ft)	50 m (164 ft)
Operating basis	modulated IR-light	
Transmit frequency (kHz)	3,7 / 3,85 / 3,97 / 4,1	
System power	automatic	
Basic transmit level	Low1 / Low2 / High1 / High2	
Switching behavior	light / dark	
Switching delay	—	
ALC delay	2 s	

Relay output	1 change over
Switching data (max.)	5A / 230 V AC (24 V DC)
Reaction time T _{ON} / T _{OFF}	Low 1: 25 ms / 25 ms High 1: 80 ms / 15 ms
Transistor output	—
Alarm output	pnp
Switching data (max.) ...AC	24 V DC / 5 mA
Switching data (max.) ...DC	24 V DC / 100 mA
Test input	—
MTBF (EN/IEC 61709)	2,7 · 10 ⁶ h (T _{ambient} = 40 °C / 104 °F)
Operating temperature	-25 ... 60 °C (-13 ... 140 °F)
Storage temperature	-40 ... 80 °C (-40 ... 176 °F)
Mounting orientation	see below
Housing material	Plastic
Housing protection	IP 40
Mounting	11-pin DIN socket
Dimensions (mm)	40 x 76,5 x 78,5

Connection Diagram



Before connecting the amplifier, look on the type plate and check if the power supply is the same as the connection value. Other values can impair the unit functions or destroy the amplifier.

Caution! The AC-supply devices are isolated from main. A grounded connection on the low voltage side is required (PIN 7).

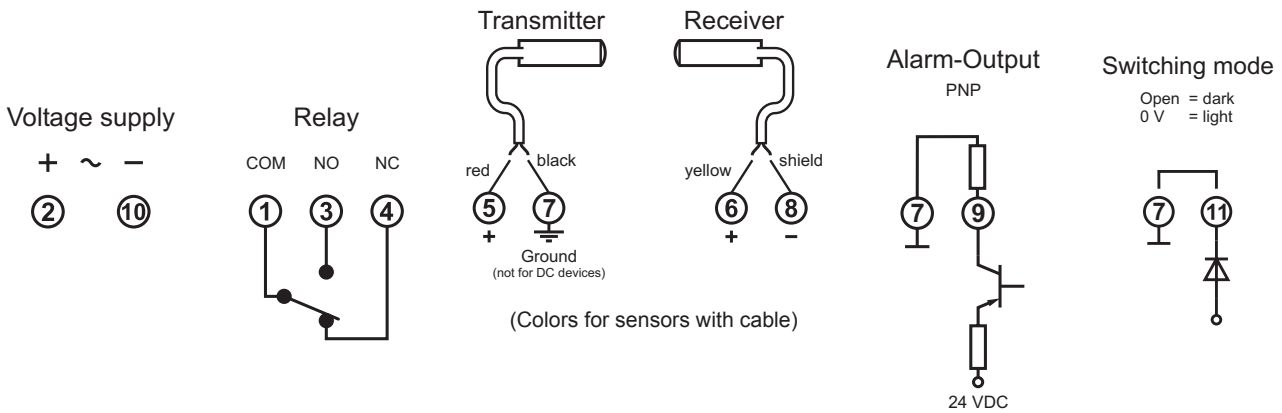

Mounting orientation



For optimum heat dissipation there are ventilation slots in the housing. Ventilation slots must be clean and opened.

Caution! Maintain the minimum distances (see picture 3: Distances).

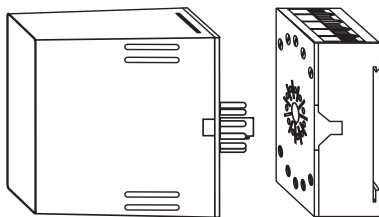

picture 1: Vertical mounting orientation, ventilation slots right

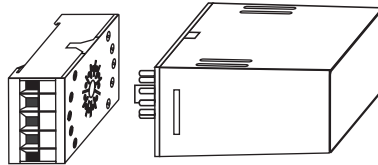

picture 2: Horizontal mounting orientation, ventilation slots top

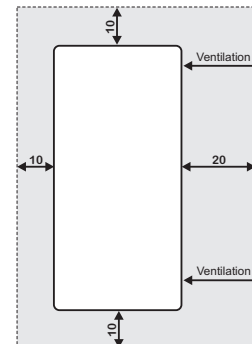

picture 3: Distances (mm)