

MINISTOP Motor Brake Relay BA 9034N



Your advantages

- Higher safety level and more economic by short stopping cycle
- Cost saving
- Compact design
- Easily appliance, no need for current measuring instrument

Features

- According to IEC/EN 60947-4-2
- For all single and 3-phase asynchronous motors
- DC-brake with one way rectification up to max. 32 A_{eff}
- Controlled by microcontroller
- Easily fitted to existing installations
- Wear free and maintenance free
- Integrated braking contactor
- DIN-rail mounting
- Adjustable braking current (controlled current)
- With automatic standstill detection
- Variante /100
 - with braking time control
 - without detection of standstill
- Width: 45 mm

Function Diagram

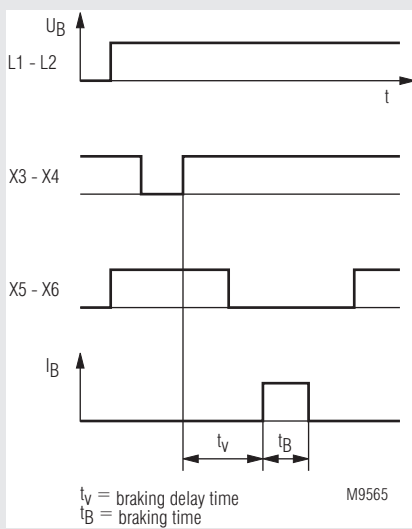

Approvals and Markings



Applications

- Saws
- Centrifuges
- Woodworking machines
- Textile machines
- Conveyors

Function

The supply voltage is connected to terminals L1-L2 and the interlock contact X5-X6 closes to enable the motor contactor. A green LED indicates operation. The motor can be started with the start button. The braking DC-voltage is generated on terminals T₁ and T₂. The braking sequence is as follows:
Pressing the stop button de-energises the motor contactor. The closing of X3-X4 (contact of the motor contactor) starts the braking. After a safety time the braking contactor closes for the adjusted braking time and the braking current flows through the motor.

Notes

Terminal 3 is the measuring input for standstill detection. The BA 9034N can be also used without connecting T3. Standstill will be detected by the current measuring. It is important to make sure, that the braking current will flow longer than 2 s before stopping the motor. If the motor stops to early, the standstill will not be detected on the braking current will flow for the maximum braking time.

To have an optimal standstill detection make sure that the braking current is greater than the nominal current of the motor.

If the back-EMF of the motor drops only slowly the unit may have a braking delay of up to 2 s.

On variant /100 the braking current flows for the adjusted time t_B.

Block Diagram

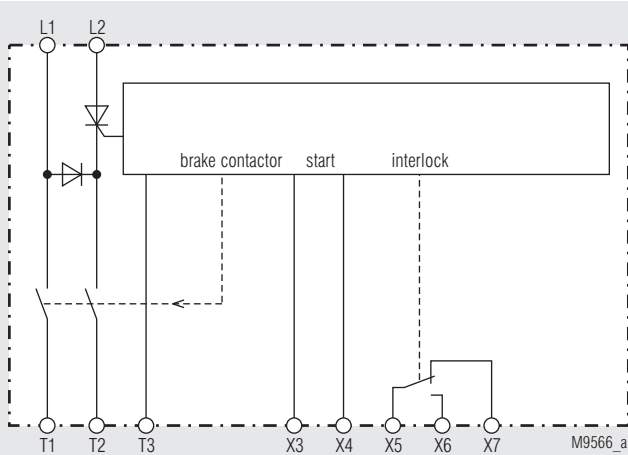

Circuit Diagram

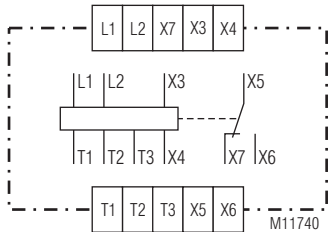

Connection Terminals

Terminal designation	Signal designation
X3	Start braking, NC contact
X4	Start braking, NC contact
X5, X6	Interlock for monitor contactor
X5, X7	Star-contactor control
L1	Phase voltage L1
L2	Phase voltage L2
T1	Motor connection T1
T2	Motor connection T2
T3	Motor connection T3 (detection of standstill)

Indicators

LED green „RUN“:	- ready:	permanent on
LED red „Error“	- Mains frequency out of tolerance	flashes 1 times
	- Braking current is not present:	flashes 2 times
	- Power semiconductors overheated:	flashes 3 times
	- Synchronisation signal is not present:	flashes 4 times
	- Temperature measuring circuit defective:	flashes 5 times
	- Motor voltage not disconnected:	flashes 6 times
LED yellow „I _B “	- max. braking time 11 s Braking current is present	permanent on
	- max. braking time 31 s Braking current is present	flashes

Technical Data

Nominal Voltage U_N:	AC 230 V ± 10 %, AC 400 V ± 10 %
Nominal frequency:	50/60 Hz ± 3 Hz
Permissible braking current:	2 ... 10 A _{eff} , 5 ... 25 A _{eff} , 5 ... 32 A _{eff}
Duty-cycle at max. braking current:	8 %
Braking voltage:	DC 10 ... 190 V
Max. braking time:	11 s
Braking delay for fade out of back EMF:	auto optimising (0.2 ... 2 s)
Nominal consumption for control circuit:	5 VA
Short circuit strength max. fuse rating:	
Line protection:	20 A gG / gL IEC/EN 60 947-5-1
Assignment type:	1 IEC/EN 60 947-4-1
Semiconductor fuse:	max. 1200 A ² s Typ gR
Assignment type:	2 IEC/EN 60 947-4-1

Output

Contacts:	1 changeover contact 5 A / AC 250 V
Switching capacity to AC 15:	
NO contact:	5 A / AC 230 V IEC/EN 60 947-5-1
NC contact:	2 A / AC 230 V IEC/EN 60 947-5-1
Electrical life:	1 x 10 ⁵ switching cycles
Mechanical life:	50 x 10 ⁶ switching cycles

General Data

Operating mode:	Continuous operation
Temperature range:	
Operation:	0°C ... + 45°C
Storage:	- 25°C ... + 75°C
Relative air humidity:	93 % at 45°C
Altitude:	< 2,000 m
Clearance and creepage distance	
Rated impulse voltage / pollution degree	
Relay contacts to supply voltage:	4 kV / 2 IEC 60 664-1
Overvoltage category:	III
EMC	
Interference resistance	
Electrostatic discharge (ESD):	8 kV (air) IEC/EN 61 000-4-2
HF irradiation:	
80 MHz ... 1.0 GHz:	10 V / m IEC/EN 61 000-4-3
1.0 GHz ... 2.5 GHz:	3 V / m IEC/EN 61 000-4-3
2.5 GHz ... 2.7 GHz:	1 V / m IEC/EN 61 000-4-3
Fast transients:	2 kV IEC/EN 61 000-4-4
Surge between wires for power supply:	1 kV IEC/EN 61 000-4-5
between wire and ground:	2 kV IEC/EN 61 000-4-5
HF wire guided:	10 V IEC/EN 61 000-4-6
Irradiation	
Interference suppression:	Limit value class B EN 55 011
Degree of protection	
Housing:	IP 40 IEC/EN 60 529
Terminals:	IP 20 IEC/EN 60 529
Housing:	Thermoplastic with V0 behaviour according to UL subject 94
Vibration resistance:	Amplitude 0.35 mm, Frequency 10 ... 55 Hz, IEC/EN 60 068-2-6
Climate resistance:	25 / 075 / 04 IEC/EN 60 068-1
Terminal designation:	EN 50 005
Wire connection:	
Cross section:	2 x 2,5 mm ² solid or 1 x 1,5 mm ² stranded ferruled DIN 46 228-1/-2/-3/-4
Stripping length:	10 mm
Wire fixing:	Flat terminals with self-lifting clamping piece IEC/EN 60 999-1
Fixing torque:	0.8 Nm
Mounting:	DIN rail IEC/EN 60 715
Weight:	600 g

Dimensions

Width x height x depth:	45 x 73 x 122 mm
--------------------------------	------------------

Standard Type

BA 9034N 25 A AC 400 V 50 / 60 Hz 2 ... 11 s

Article number: 0061337

- Integrated braking contactor
- DIN-rail mounting
- Width: 45 mm

Variant

BA 9034N/100: without standstill monitoring and with potentiometer for setting of braking delay time up to 15 s

Ordering example for variant

BA 9034N /100 25 A AC 400 V 50 / 60 Hz

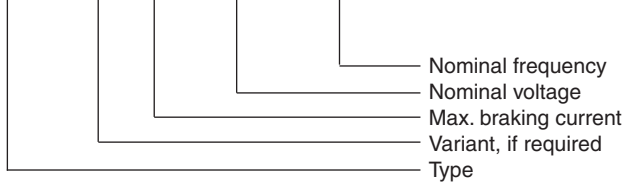

Control Input

If the connection between X3-X4 is opened, the device turns into standby mode. After closing the connection, the device starts with braking. The device can be started also without control on X3-X4. In this case the braking delay is slightly longer up to 1.5 s.

Monitoring Output

- X5, X6: Interlock contact for motor contactor. This contact will be open at system error, this means that the motor cannot be started!
- X5, X7: Activation of the star contactor in a star-delta circuit during braking

Adjustment Facilities

Potentiometer	Description	Initial setting
I_B	Braking current	Fully anti-clockwise

Variant /100:

Potentiometer	Description	Initial setting
T_B	Braking delay time	Fully clockwise

The braking current is controlled according to the adjusted value in Ampere.

For optimum braking the setting of the current should be max. 1.8 to 2 times the motor current. This corresponds to the saturation current of the magnetic field used to brake the motor. A higher current only overheats the motor. A higher braking efficiency can be obtained by using 2 or more stator windings. The permitted duty cycle is depending on the actual braking current and the ambient temperature.

Connection Examples

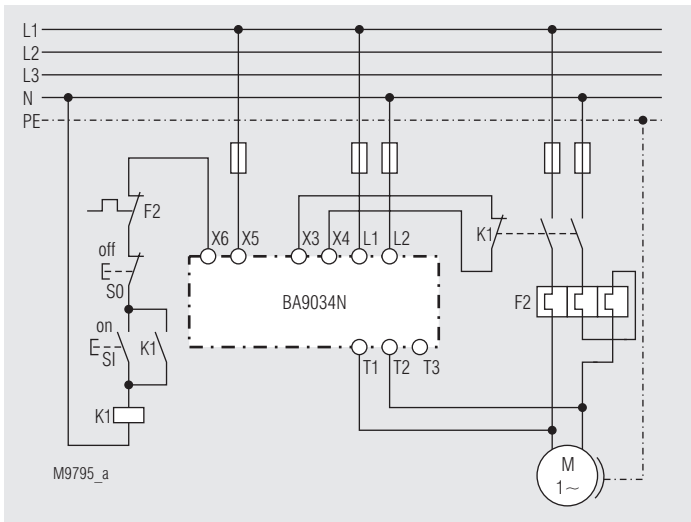

BA 9034N, single-phase

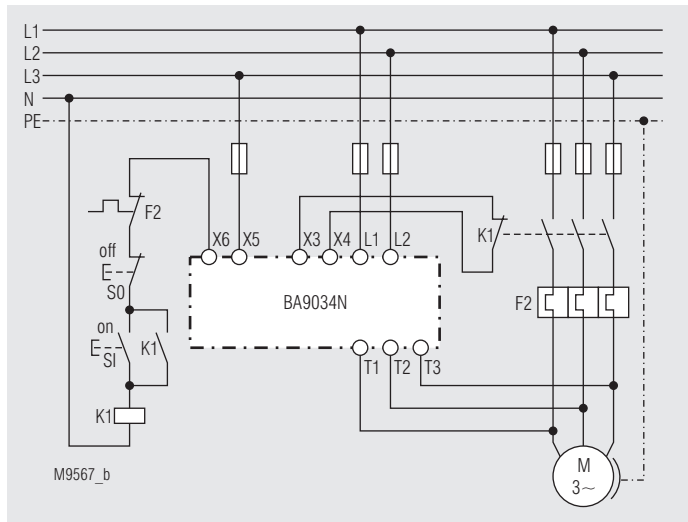

BA 9034N, 3-phase

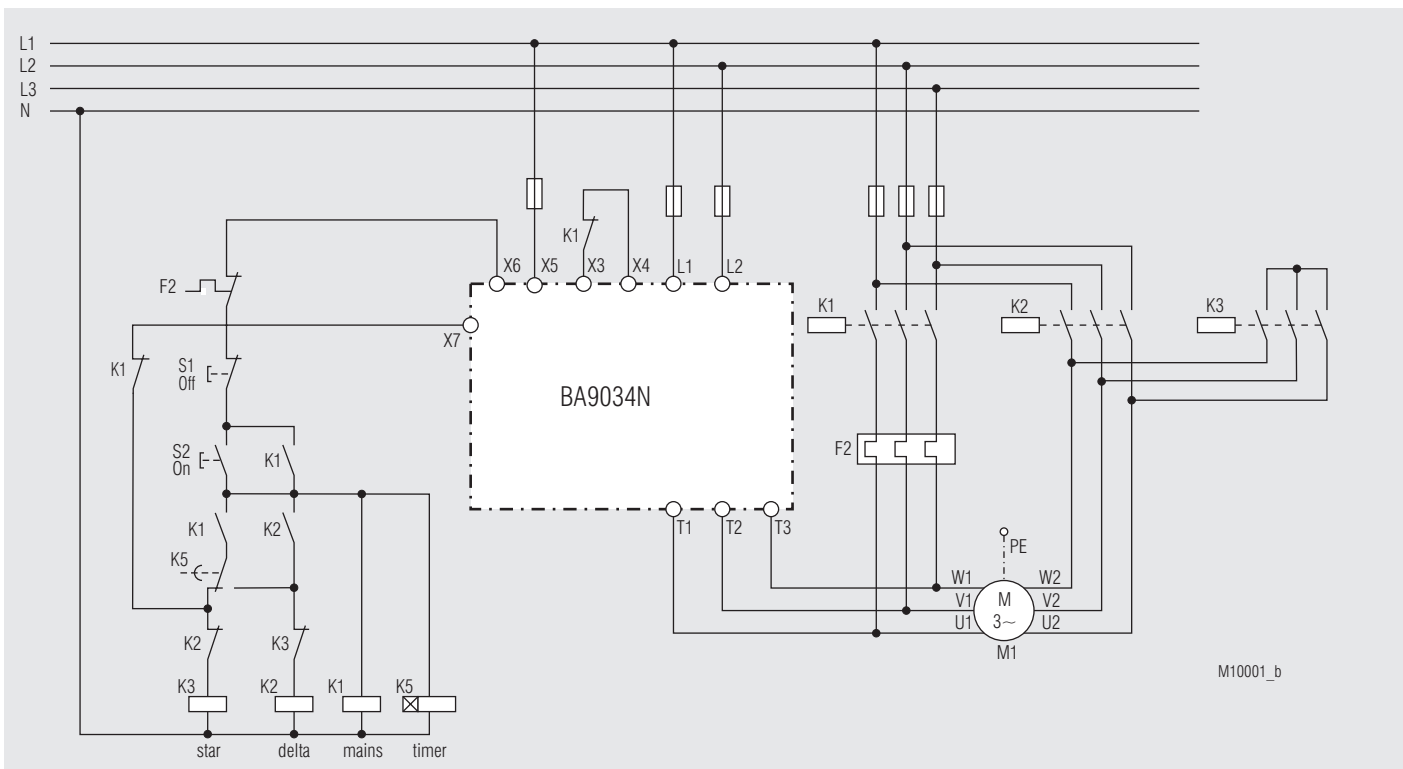

BA 9034N, 3-phase, $\star\Delta$ -start up

Connection Example

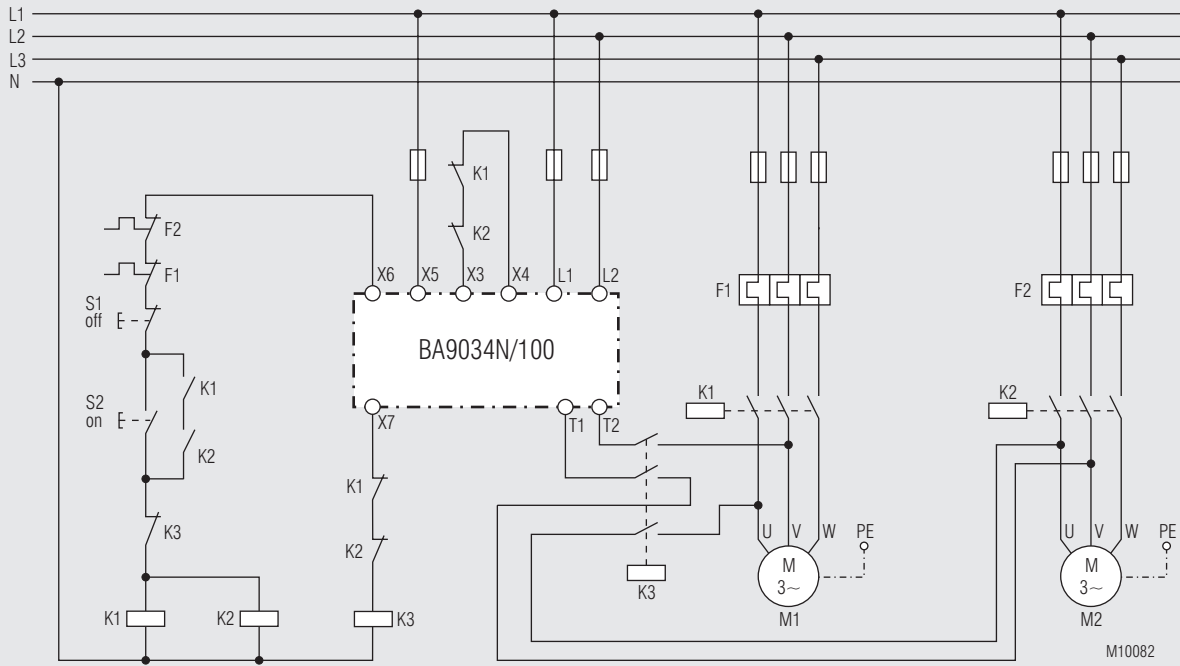

BA 9034N/100 simultaneous braking of 2 motors in serial connection for higher motor loads

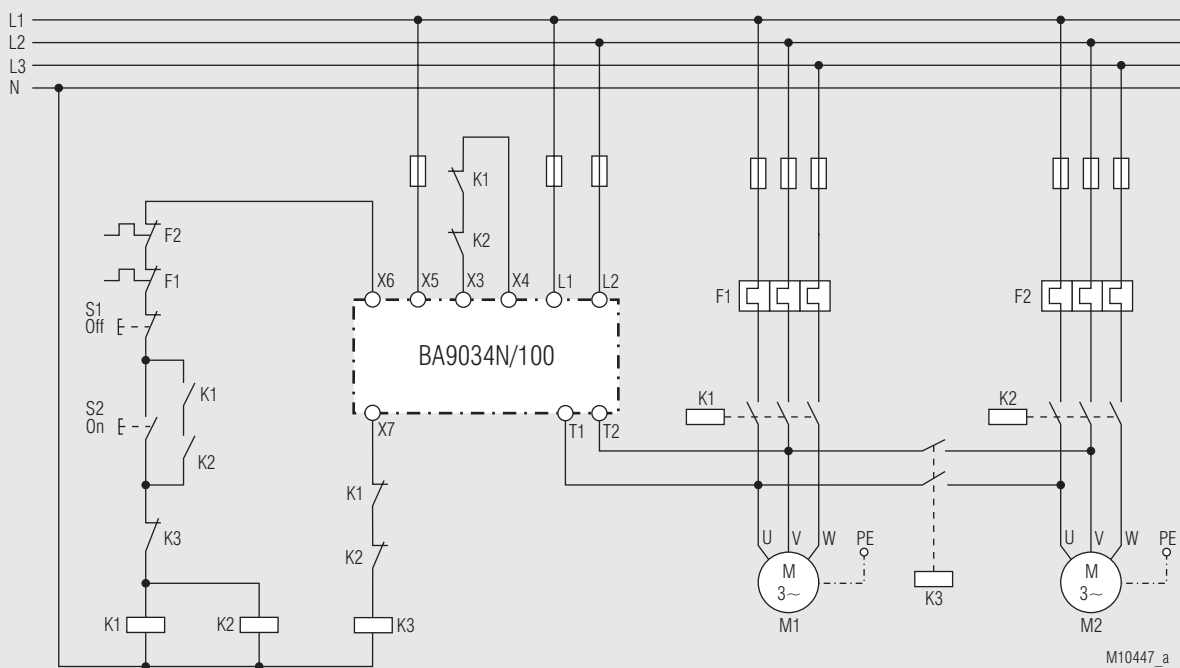

BA 9034N/100 simultaneous braking of 2 motors in parallel connection for lower motor loads

Set-up Procedure

- Connect the motor braking relay BA 9034N in accordance to the connection example and make sure to connect the same phases between (L1, L2) and /T1, T2). Make sure that the interlocking contact X5, X6 is wired in series to the coil of the motor contactor so that the motor contactor cannot switch on, while the braking current is flowing
- Set the braking current in the potentiometer scale.
To avoid overloading of the motor set the current to max. two times the nominal motor current
- The braking time of the BA 9034N cannot be adjusted. Due to the standstill detection it is self-optimizing. If L3 is not connected to T3 standstill detection is provided by measuring the braking current.
- If no standstill is detected, the BA 9034N stops braking after 10 s

Fault Indication by Flashing Code

During normal operation failure messages may occur. The messages are indicated by a flashing sequence of the „Error“ LED

Flashes	Fault	Reason	Failure recovery
1 x	Mains frequency out of tolerance	Wrong mains frequency	Device not suitable for the frequency. Contact manufacturer
2 x	Braking current is not present	Braking current circuit broken Motor coil resistance is too high	Check the wiring Set braking current lower until the error disappears
3 x	Power semiconductors overheated	Permitted duty cycle exceeded	Decrease current and set the braking time longer. Wait till heat sink cools down
4 x	Synchronisations signal is not present	Unit defective or temporary interruption of power supply	The unit has to be repaired Switch unit Off and On
5 x	Temperature measuring circuit defective	Unit defective or overtemperature on power semiconductors while switching on	The unit has to be repaired Wait till heat sink cools down
6 x	Motor is still connected to voltage while braking should start already	Motor contactor welded Wiring incorrect	Change motor contactor Check wiring
7 x	Braking relay is welded	Unit defective	The unit has to be repaired